

SIMOPAC® MODULE

- Half bridge power MOSFET module
- N channel, enhancement mode
- Avalanche rated
- Package with insulated metal base plate

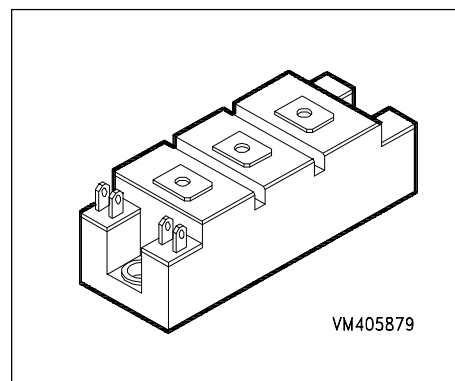

Type	V_{DS}	I_D	$R_{DS(on)max}$	Package	Ordering Code
BSM 214 A	100 V	125 A	0.013 Ω	HB MOS 1	C67076-S1100-A20

Maximum Ratings

Parameter	Symbol	Values	Unit
Drain source voltage	V_{DS}	100	V
Drain-gate voltage	V_{DGR}	100	
$R_{GS} = 20 \text{ k}\Omega$			
Gate source voltage	V_{GS}	± 20	
Continuous drain current	I_D	125	A
$T_C = 25 \text{ }^\circ\text{C}$			
DC drain current, pulsed	I_{Dpuls}	375	
$T_C = 25 \text{ }^\circ\text{C}$			
Power dissipation	P_{tot}	400	W
$T_C = 25 \text{ }^\circ\text{C}$			
Chip temperature	T_{jmax}	150	$^\circ\text{C}$
Storage temperature	T_{stg}	-40 ... + 125	

Thermal resistance chip - case	R_{thJC}	≤ 0.31	K/W
Thermal resistance case - heat sink	R_{thCA}	≤ 0.07	
Insulation test voltage, $t = 1 \text{ min}$	V_{is}	2.5	kV ac
Creepage distance, drain-source		16	mm
Clearance, drain-source		11	
DIN humidity category, DIN 40 040		F	
DIN humidity category, DIN IEC 68-1		40 / 125 / 56	

Electrical Characteristics, at $T_j = 25^\circ\text{C}$, unless otherwise specified

Parameter	Symbol	Values			Unit
		min.	typ.	max.	
Static Characteristics					
Gate threshold voltage $V_{GS} = V_{DS}, I_D = 1 \text{ mA}$	$V_{GS(th)}$	2.1	3	4	V
Drain-Source on-resistance $V_{GS} = 10 \text{ V}, I_D = 72 \text{ A}$	$R_{DS(on)}$	-	0.01	0.013	Ω
Zero gate voltage drain current $V_{DS} = 100 \text{ V}, V_{GS} = 0 \text{ V}, T_j = 25^\circ\text{C}$ $V_{DS} = 100 \text{ V}, V_{GS} = 0 \text{ V}, T_j = 125^\circ\text{C}$	I_{DSS}	-	50 300	100 1000	μA
Gate-source leakage current $V_{GS} = 20 \text{ V}, V_{DS} = 0 \text{ V}$	I_{GSS}	-	10	100	nA

Reverse Diode

Inverse diode continuous forward current $T_C = 25^\circ\text{C}$	I_S	-	-	125	A
Inverse diode direct current, pulsed $T_C = 25^\circ\text{C}$	I_{SM}	-	-	375	
Inverse diode forward voltage $V_{GS} = 0 \text{ V}, I_F = 250 \text{ A}$	V_{SD}	0.65	1.2	1.4	V
Reverse recovery time $V_R = 30 \text{ V}, I_F = I_S, di_F/dt = 100 \text{ A}/\mu\text{s}$	t_{rr}	-	350	-	ns
Reverse recovery charge $V_R = 30 \text{ V}, I_F = I_S, di_F/dt = 100 \text{ A}/\mu\text{s}$	Q_{rr}	-	3.6	-	μC

Electrical Characteristics, at $T_j = 25^\circ\text{C}$, unless otherwise specified

Parameter	Symbol	Values			Unit
		min.	typ.	max.	
Dynamic Characteristics					
Transconductance $V_{DS} \geq 2 * I_D * R_{DS(on)max}$, $I_D = 72\text{ A}$	g_{fs}	40	60	-	S
Input capacitance $V_{GS} = 0\text{ V}$, $V_{DS} = 25\text{ V}$, $f = 1\text{ MHz}$	C_{iss}	-	9	12	nF
Output capacitance $V_{GS} = 0\text{ V}$, $V_{DS} = 25\text{ V}$, $f = 1\text{ MHz}$	C_{oss}	-	4	6	
Reverse transfer capacitance $V_{GS} = 0\text{ V}$, $V_{DS} = 25\text{ V}$, $f = 1\text{ MHz}$	C_{rss}	-	1.6	2.4	
Turn-on delay time $V_{DD} = 50\text{ V}$, $V_{GS} = 10\text{ V}$, $I_D = 72\text{ A}$ $R_{GS} = 3.3\ \Omega$	$t_{d(on)}$	-	220	-	ns
Rise time $V_{DD} = 50\text{ V}$, $V_{GS} = 10\text{ V}$, $I_D = 72\text{ A}$ $R_{GS} = 3.3\ \Omega$	t_r	-	220	-	
Turn-off delay time $V_{DD} = 50\text{ V}$, $V_{GS} = 10\text{ V}$, $I_D = 72\text{ A}$ $R_{GS} = 3.3\ \Omega$	$t_{d(off)}$	-	220	-	
Fall time $V_{DD} = 50\text{ V}$, $V_{GS} = 10\text{ V}$, $I_D = 72\text{ A}$ $R_{GS} = 3.3\ \Omega$	t_f	-	60	-	

Power dissipation

$P_{tot} = f(T_C)$

parameter: $T_j \leq 150\text{ }^\circ\text{C}$

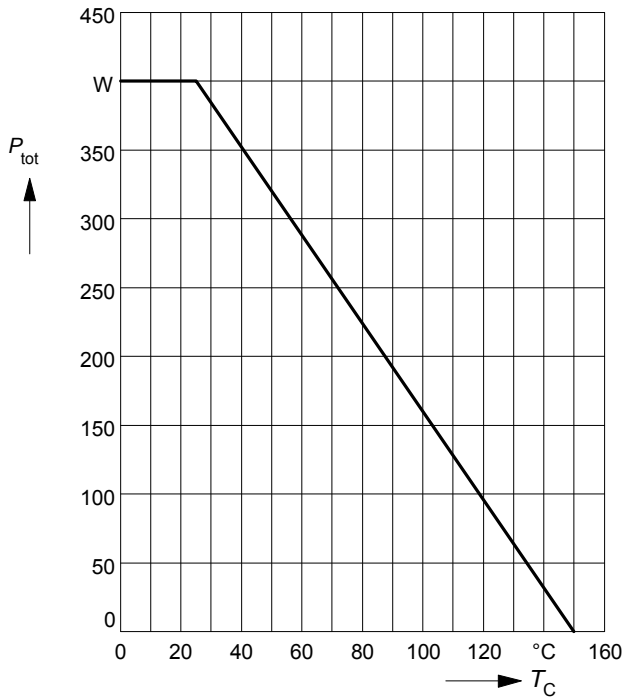

Drain current

$I_D = f(T_C)$

parameter: $V_{GS} \geq 10\text{ V}$, $T_j \leq 150\text{ }^\circ\text{C}$

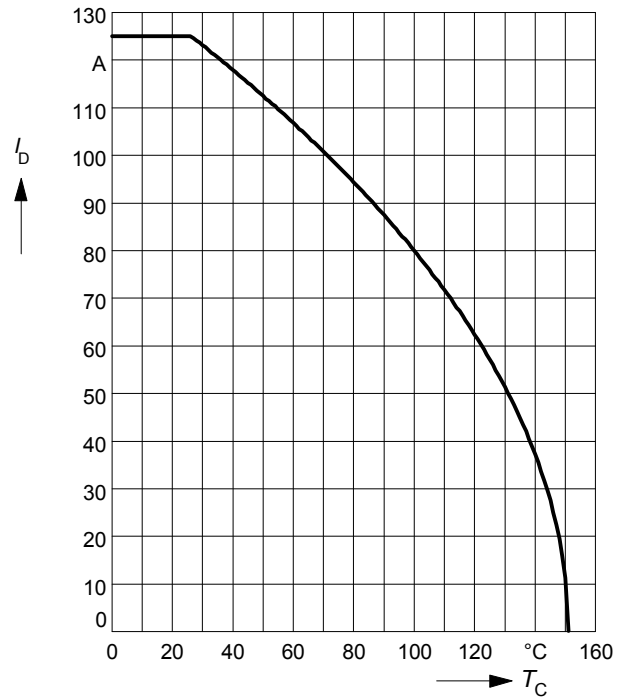

Safe operating area

$I_D = f(V_{DS})$

parameter: *single puls*, $T_C = 25\text{ }^\circ\text{C}$, $T_j \leq 150\text{ }^\circ\text{C}$

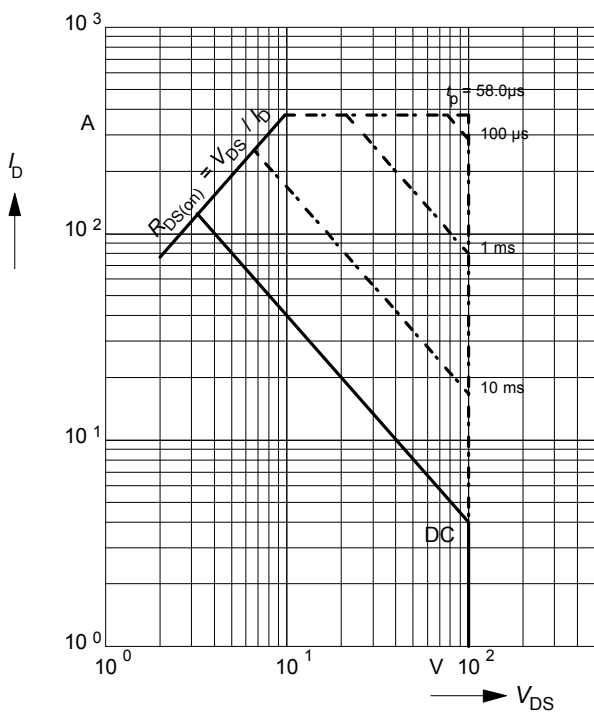

Transient thermal impedance

$Z_{thJC} = f(t_p)$

parameter: $D = t_p / T$

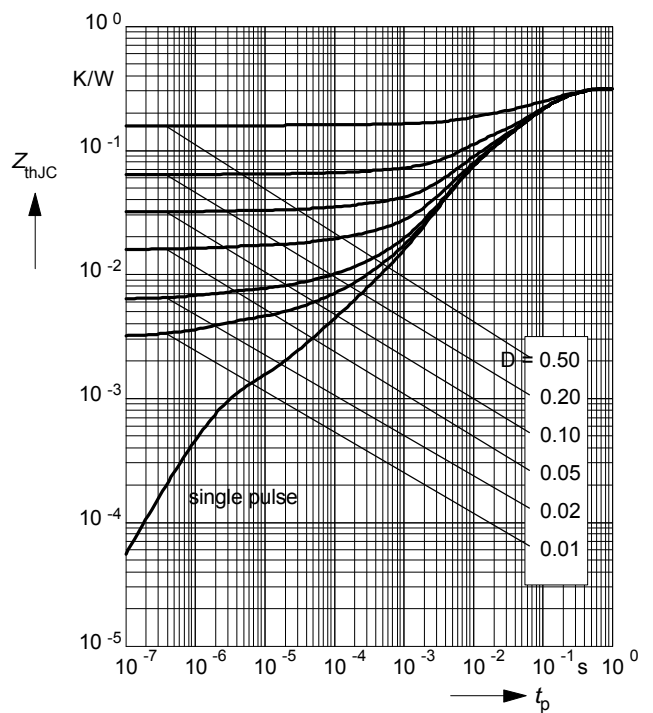

Typ. output characteristics

$I_D = f(V_{DS})$

parameter: $t_p = 80 \mu s$, $T_j = 25 \text{ }^\circ\text{C}$

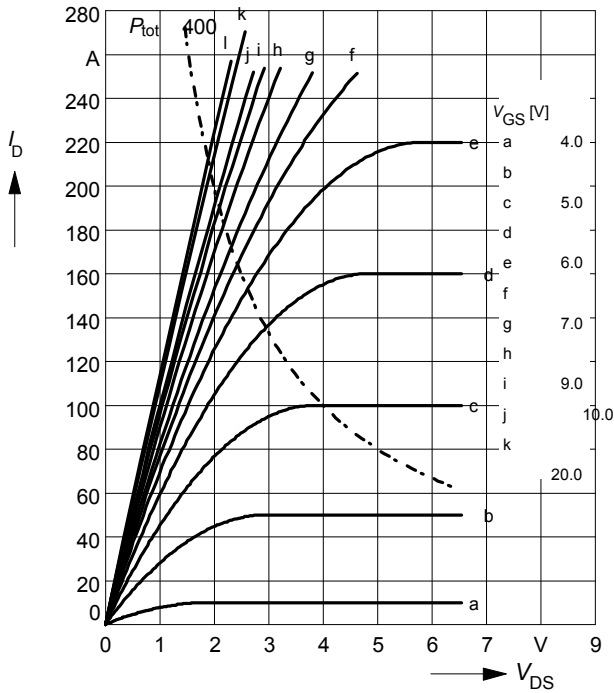

Gate threshold voltage

$V_{GS(th)} = f(T_j)$

parameter: $V_{GS} = 10 \text{ V}$, $I_D = 1 \text{ mA}$

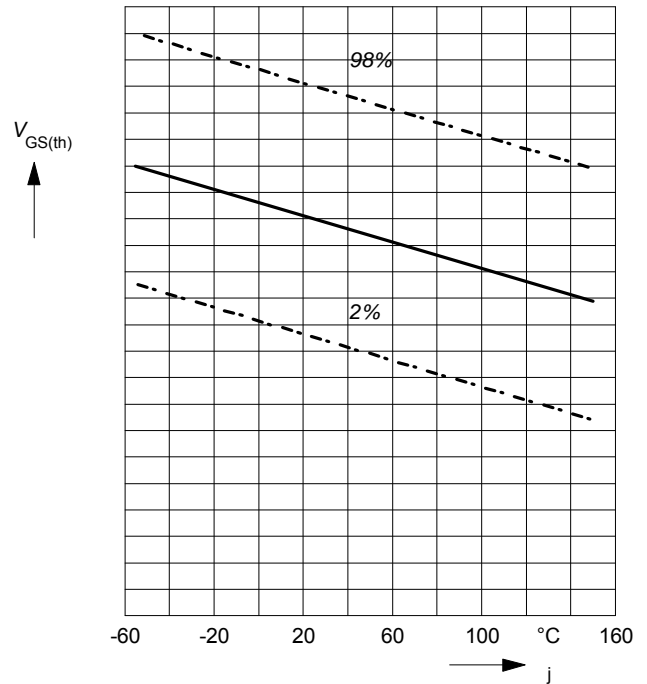

Typ. transfer characteristic

$I_D = f(V_{GS})$

parameter: $t_p = 80 \mu s$, $V_{DS} = 25 \text{ V}$

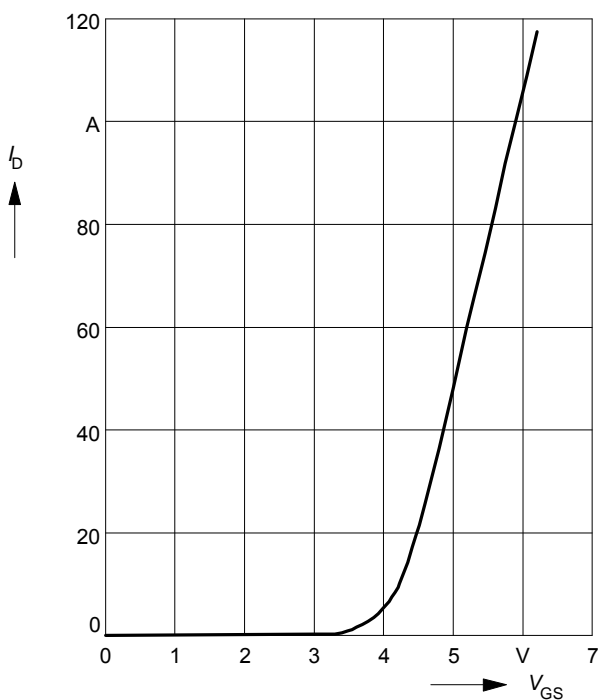

Forward characteristics of reverse diode

$I_F = f(V_{SD})$

parameter: T_j , $t_p = 80 \mu s$

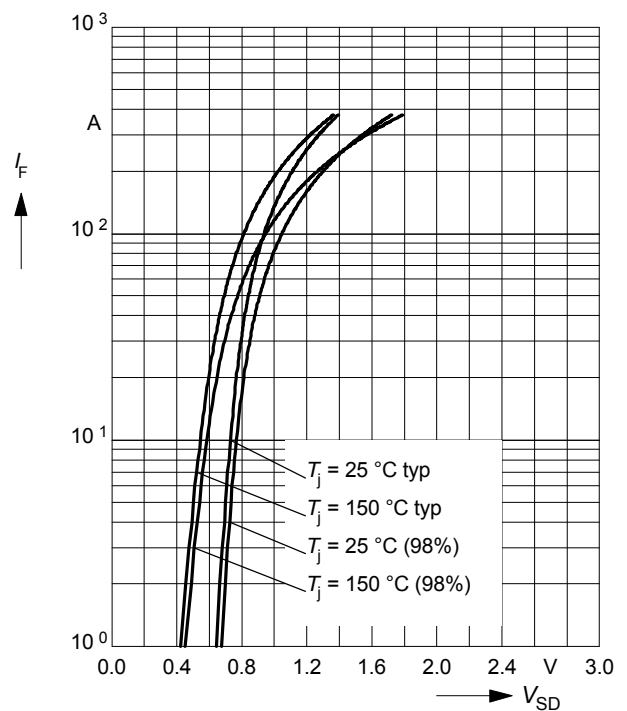

Drain-source on-resistance

$$R_{DS(on)} = f(T_j)$$

parameter: $I_D = 72\text{ A}$, $V_{GS} = 10\text{ V}$

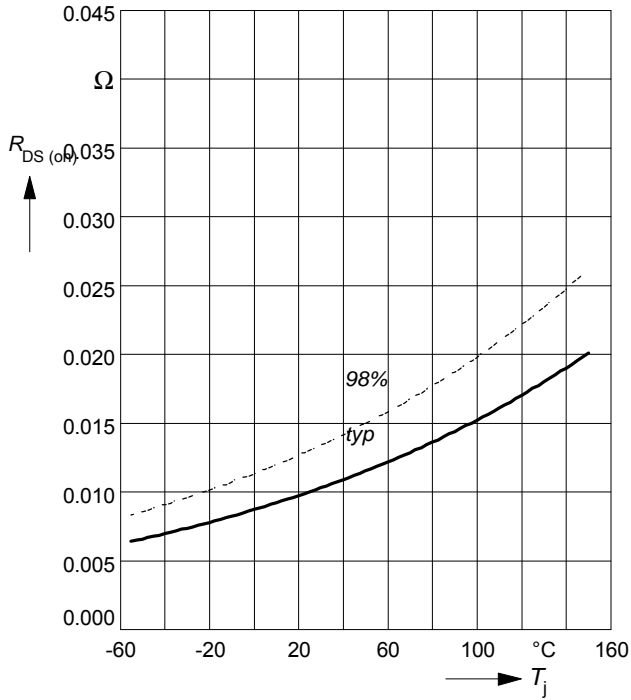

Drain-source breakdown voltage

$$V_{(BR)DSS} = f(T_j)$$

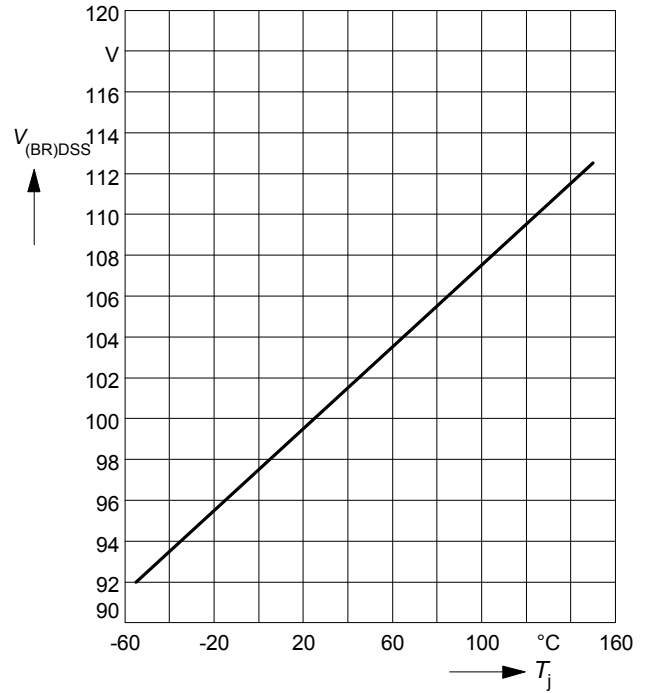

Typ. gate charge

$$V_{GS} = f(Q_{Gate})$$

parameter: $I_{D\text{ puls}} = 185\text{ A}$

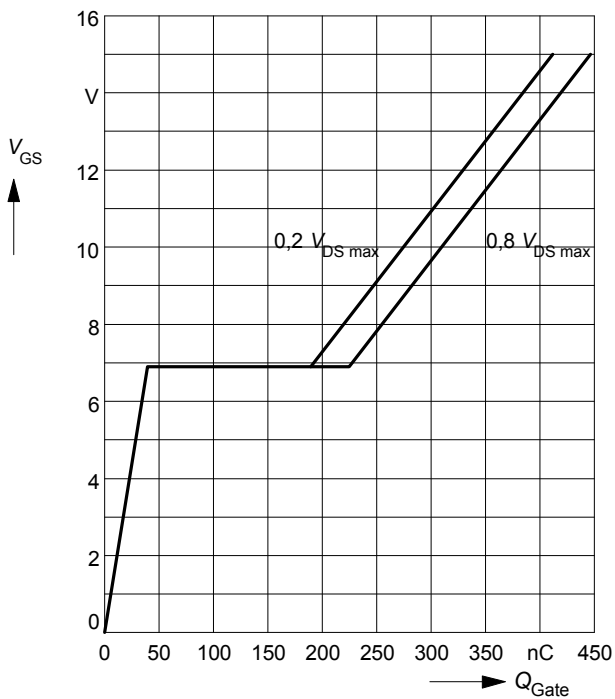

Typ. capacitances

$$C = f(V_{DS})$$

parameter: $V_{GS} = 0\text{ V}$, $f = 1\text{ MHz}$

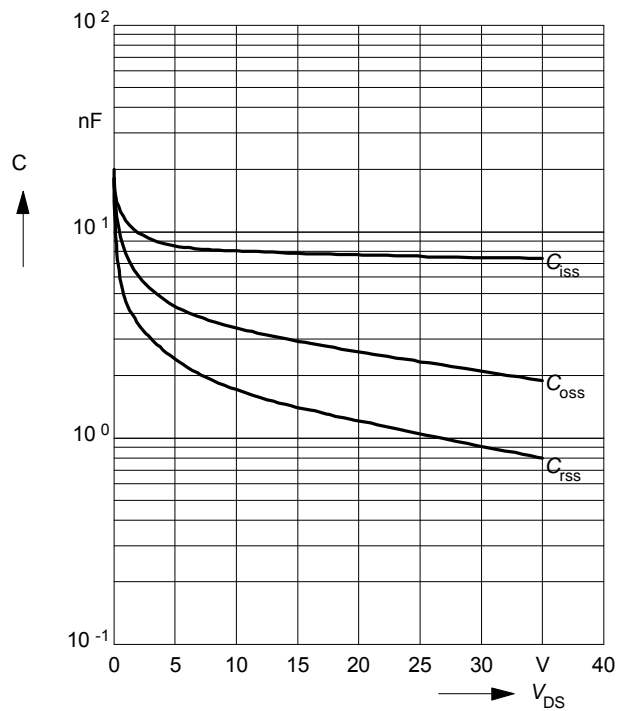

Circuit Diagramm

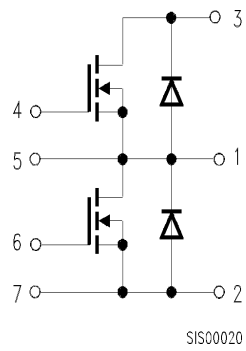

Package Outlines

Dimension in mm

Weight: 160 g

